

## Frozen Frozen Cream Dispenser, 1x2 L bowl

ITEM # \_\_\_\_\_

MODEL # \_\_\_\_\_

NAME # \_\_\_\_\_

SIS # \_\_\_\_\_

AIA # \_\_\_\_\_

**560020 (NINA1)**

 Frozen Cream Dispenser  
with 1x2 l bowl

**560021 (NINAIITNK)**

 Frozen Cream Dispenser  
with 1x2 l insulated bowl

### Short Form Specification

**Item No.** \_\_\_\_\_

Mini dispenser for cold creams and sherbets with 1 tank of 2lt of finished product. Small dimension of the tank grants a more frequent renewal of the product inside of it for a higher freshness. Special fire-resistant plastic frame composed of ABS & Polycarbonate, steel side panels. Works with air cooling system.

### Main Features

- Mini dispenser for cold creams and sorbet.
- 1 tank of 2lt of finished product.
- Ideal for the operators who have little space available and small sales volumes, it is also perfect for off-season use, when frozen product demand is low.
- Small dimension of the tank grants a more frequent renewal of the product inside of it for a higher freshness.
- Adjustable temperature from - 3°C up to -6°C.

### Construction

- Special fire-resistant plastic frame composed of ABS & Polycarbonate, steel side panels.
- Works with air cooling system.

**APPROVAL:** \_\_\_\_\_

Front

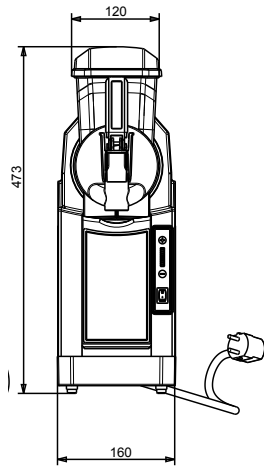

Side

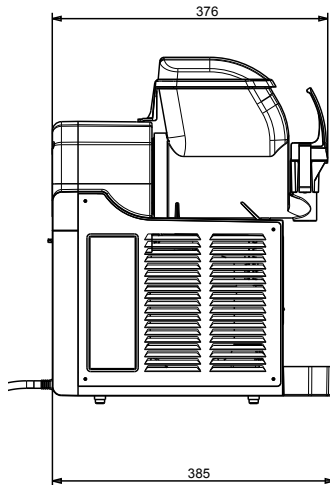

Top

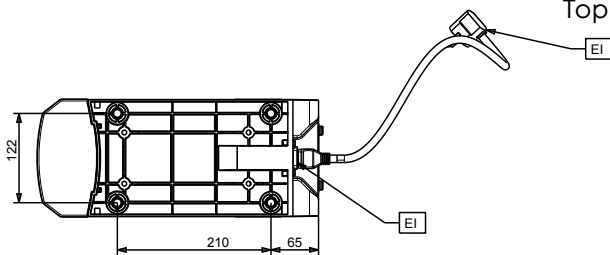

## Electric

### Supply voltage:

560020 (NINA1) 220-240 V/1 ph/50 Hz

560021 (NINA1ITNK) 220-240 V/1 ph/50 Hz

Electrical power max.: 0.23 kW

## Key Information:

External dimensions, Width: 160 mm

External dimensions, Depth: 385 mm

External dimensions, Height: 473 mm

Net weight: 15 kg

## Refrigeration Data

Refrigerant type: R134a